

BIG SKY

TROOPER™



INSTRUCTION BOOKLET



SUPER NINTENDO
ENTERTAINMENT SYSTEM

WARNING: PLEASE READ THE ENCLOSED CONSUMER INFORMATION AND PRECAUTIONS BOOKLET CAREFULLY BEFORE USING YOUR NINTENDO® HARDWARE SYSTEM OR GAME PAK.

THIS PRODUCT HAS BEEN RATED BY THE ENTERTAINMENT SOFTWARE RATING BOARD. FOR INFORMATION ABOUT THE ESRB RATING, OR TO COMMENT ABOUT THE APPROPRIATENESS OF THE RATING, PLEASE CONTACT THE ESRB AT 1-800-771-3772.

NEED MORE HELP?

CALL JVC'S 24-HOUR TIP LINE: 1-900-454-4JVC (USA),
1-900-451-5JVC (Canada)

75¢ each minute. If you are under 18, be sure to get a parent's permission before calling. Requires a touch-tone telephone and is only available in the U.S. and Canada. Call length determined by user; average length is 3 minutes. Messages subject to change without notice.

JVC Musical Industries, Inc., Los Angeles, CA 90068



LICENSED BY



NINTENDO, SUPER NINTENDO ENTERTAINMENT SYSTEM AND THE OFFICIAL SEALS ARE REGISTERED TRADEMARKS OF NINTENDO OF AMERICA INC. ©1991 NINTENDO OF AMERICA INC.

THIS OFFICIAL SEAL IS YOUR ASSURANCE THAT NINTENDO HAS APPROVED THE QUALITY OF THIS PRODUCT. ALWAYS LOOK FOR THIS SEAL WHEN BUYING GAMES AND ACCESSORIES TO ENSURE COMPLETE COMPATIBILITY. ALL NINTENDO PRODUCTS ARE LICENSED BY SALE FOR USE ONLY WITH OTHER AUTHORIZED PRODUCTS BEARING THE OFFICIAL NINTENDO SEAL OF QUALITY.

CONTENTS

TROOPER ALERT...BACKGROUND BRIEFING	2
STARTING THE GAME	3
NAMES OF CONTROLLER PARTS	4
BUTTON CONTROLS	5
SHIP OPERATIONS	6
TROOPER ALERT...STRATEGY TIPS	10
ITEMS	12
MAPS	14

TROOPER ALERT... BACKGROUND BRIEFING...TROOPER ALERT

Goopy green gastropods from beyond the stars have discovered the human race! And they're so disgusted by our bones and bad habits that they've declared total war! Lured by a sly military recruiter, you sign a simple contract, and the next thing you know you're a 21-Star General in the Big Sky Troopers, off on a loony adventure to save the world from the Sultan of Slime and his alien armada.

There are two obstacles on the road to glory; first, it turns out you're the only one brave (or dumb) enough to volunteer for duty, and second, the Slugs have sabotaged the ancient machinery that operates reality. So... even with a star-hopping battle cruiser to carry you into action, a deadly laser gun to wield, and a computer sidekick named FIDO to keep you out of trouble, you can't simply out-fight the enemy -- you must also solve the mystery of the universe if you hope to lead Earth's forces to victory.

STARTING THE GAME

1. Turn off your Super Nintendo Entertainment System by sliding the POWER bar away from the Game Pak slot. Plug a game controller into your system.
2. Insert the *Big Sky Trooper* Game Pak, label facing front, in the system slot.
3. Turn on the system by sliding the POWER bar toward the system slot.
4. When the Title screen appears, press the START Button to begin play.
5. Choose your character (male or female) with the A or START button.
6. If you have previously saved a game, you may restore this game by choosing the BST Combat Suit icon in the middle, then selecting the saved game you wish to play.



NAMES OF CONTROLLER PARTS

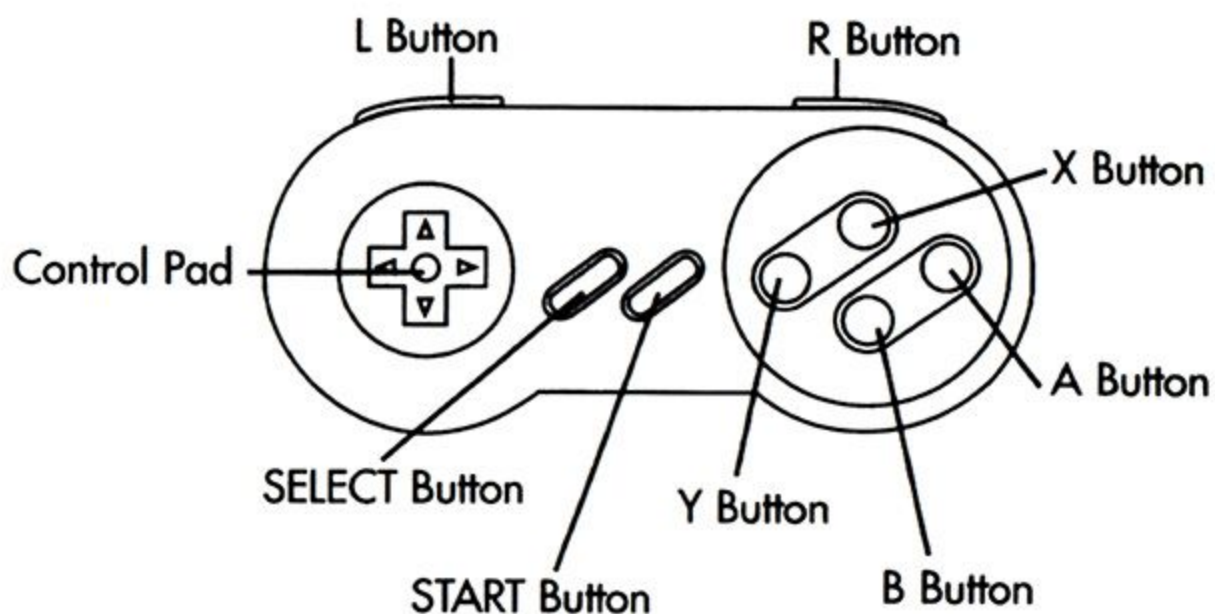

This manual refers to the following directions:



BUTTON CONTROLS

- A button- pick up items, activate switches, talk to characters, arrange suit modules, fire rocket thrusters (in space battle)- it's an all purpose "DO" command
- B button- fire standard weapons, speed through most text and animation displays, back out of display modes
- X button- use combat suit module powerups (after configuring them in the inventory screen)
- Y button- Use selected inventory item

SHIP OPERATIONS

USING THE VIEWSCREEN

Walk up to your ship's viewscreen and press the A button. FIDO will appear. Select the display mode you want with your control pad, then press A again.



TALK TO FIDO

You can ask FIDO about items in your inventory. FIDO has lots of useful hints and information. It's **IMPORTANT** to ask him about any new item you collect.

SHIP OPERATIONS



GO TO SKYWAY MAP

Use this map to travel around the Big Sky Galaxy. Move the cursor to a destination planet. If the cursor flashes GREEN, you can go there by pressing the A button. If the cursor flashes RED, the planet is out of range, and you need to install a Cosmic Transport Relay.

- You can travel to ANY planet that already has a relay. Double green cursors reveal their presence on the map.
- If the planet you're on has a Relay, you can travel to any ADJACENT planet, whether it has a Relay or not. But you can't reach distant planets that don't have them. The RED cursor shows which planets are off limits.



GO TO VIEWPORT

The Viewport shows the planet or space station that the Dire Wolf (your spaceship) is currently orbiting. You can deploy or retrieve Cosmic Transport Relays by pressing the A button.

SHIP OPERATIONS



MISSION ORDERS

FIDO hands out new mission orders (and a promotion!) every time you complete a mission. Keep focused on your next objective and you can't go wrong!



BEAMING DOWN

During the game you will need to beam down to planets and space stations to pick up items or defeat occupying slugs. To do this, stand in the middle of the AIRLOCK and press the A button.

SHIP OPERATIONS



SAVING GAMES

To save your game, move your character to one of the four SLEEP CHAMBERS on your ship and press the A button. The numbers on the sleep chambers correspond to the save game numbers at the beginning of the game.



BATTLE SCREEN

When you arrive at a planet occupied by Slugs, you must defeat their space patrols, or be forced to retreat to your previous location. Use the A button to fire rocket thrusters and the B button to fire torpedoes. As you progress through the game you will receive spaceship powerups. Give them to FIDO to install. Two of the powerups are special weapons. Launch and explode SPACE MINES by pressing and releasing the Y button. Launch and explode QUARK TORPEDOES by pressing and releasing the X button.

TROOPER ALERT...STRATEGY TIPS



1. Sergeant Slack hangs out at the space station in the center of the Galaxy where you start the game. Once you make friends with him, go to see him as soon as you get a promotion, and he'll upgrade the armor on your Combat Suit.



2. Cosmic Transport Relays are your key to fast travel around the Galaxy. Place them on or near key planets and you'll navigate the spaceways with ease.



3. Slugs hate Fast Food. Slugs often reconquer a planet once you've left it, but once you establish a Fast Food Franchise on a planet (look for the double-F marks!), they'll never go near it again.

TROOPER ALERT...STRATEGY TIPS



4. Look for cliffs and walls that can be blasted with Star Fuel Drums. Valuable items may be on the other side.



5. Be on the lookout for mailboxes. They contain info from a fellow secret agent that will help your mission.



6. Listen to the SPIRIT of the planet when you see one. Do what they ask, and they will give you a valuable treasure from their planet.

ITEMS

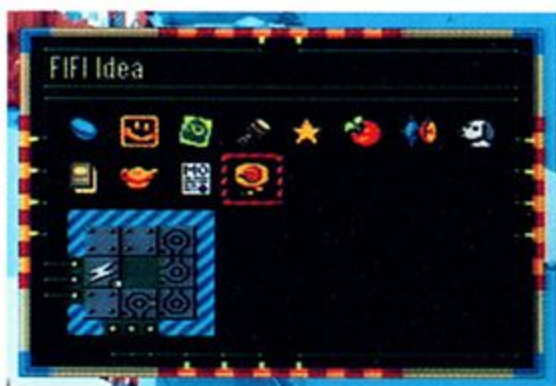

Here are a few basic items that you will encounter during your adventure.

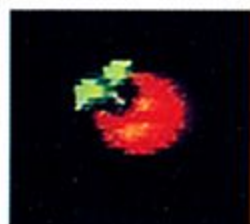

HEALTH FRUITS (Neenapods)- Use with the First Aid Station onboard the Dire Wolf to restore your health.



FIDO UPLINK- Use this to have FIDO beam you back to the Dire Wolf from planets and dungeons.



NEON SIGN- Slugs hate advertising! They lose two eyes when they touch these signs.

ITEMS

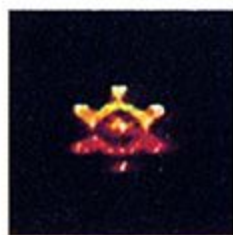

LUCKY CHARM- Use these to trade for other goods.



ANCIENT ARTIFACT- Use these to trade for other goods.

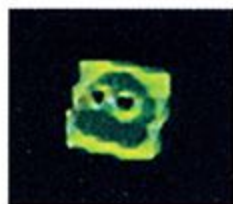

SLUG TRADING CARDS- Use these to trade for other goods. These are especially valuable on the Slug Flagship.



STATUS STAR- This tells your rank.



OPENING WALKTHRU

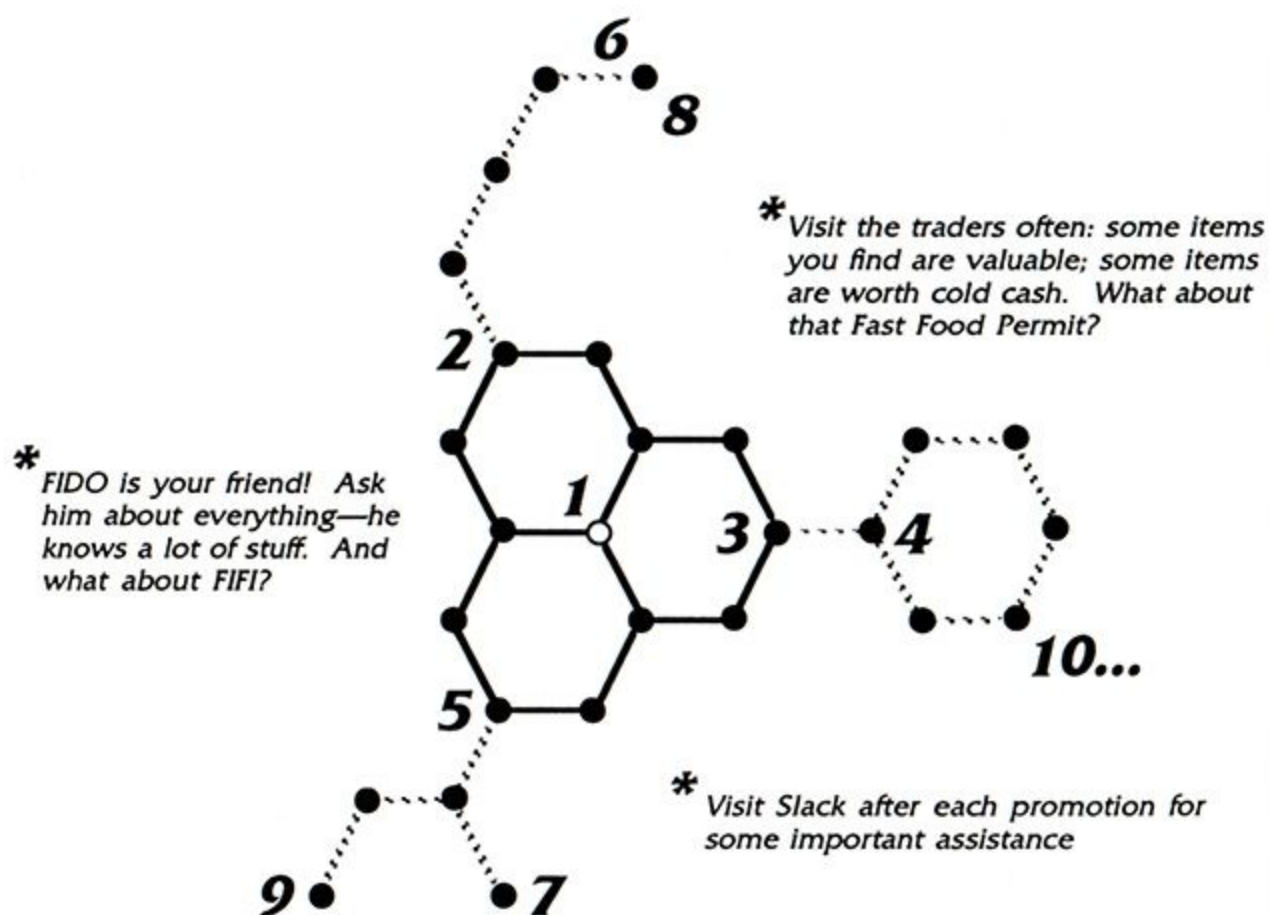

1. Meet Supply Specialist Slack—try to befriend him
2. Rescue the Secret Agent—get Electrokey
3. Find 1st Map Chip for FIDO—your world expands
4. Talk to the Spirit of the Planet—get Medal for Slack
5. Talk to the Spirit of the Planet—get Brass Lamp
6. Trade with Black Market Max—get Diamond Ring
7. Trade with Bargain Bob—get Silver Spoon
8. Trade with Max again—get Suit Module #1
9. Restore the Sunshine Machine
10. Find 2nd Map Chip—now you're on your own

Suit Module Combos

NOTE: The combat suit is a tricky piece of high-tech equipment that requires skill & Ingenuity to configure...

THE MODULES:

 - spacer (position Irrelevant)

 - blocker (position Irrelevant)

 - Power Pack
(can vary from positions shown--as long as the sockets connect)

 - Suit Module #1

 - Suit Module #2

 - Suit Module #3

 - Suit Module #4

DIAGRAM OF MODULE ASSEMBLY :

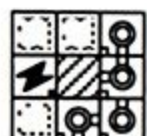
 - configuration at startup, and a good neutral position that eases transitions to most of the useful combinations

  - MAGNET HANDS ENABLED
(power + #2 + #3)
• push & pull objects

 - SNORKEL ENABLED
(power + #1)
• swim underwater

 - POWER BALL ENABLED
(power + #1 + #2 + #3)
• more powerful weapon

 - JET PACK ENABLED
(power + #2)
• fly through space

 - SELF REPAIR ENABLED
(power + #1 + #4)
• convert battery power to health

 - CAMOUFLAGE ENABLED
(power + #3)
• look like the enemy

 - SUPER SHIELD ENABLED
(power + #3 + #4)
• deflect enemy blows

 - ICE RAY ENABLED
(power + #4)
• freeze enemies & lava

 - SWEEP SHOT ENABLED
(power + #2 + #3 + #4)
• more powerful weapon

 - BOUNCE SHOT ENABLED
(power + #1 + #2)
• more powerful weapon

 - TACTICAL NUKE ENABLED
(power + #1 + #2 + #3 + #4)
• ka-boom!

SKYWAY MAP

○ - Sergeant Slack ● - Face of Space ▼ - Fast Food Survey Mark

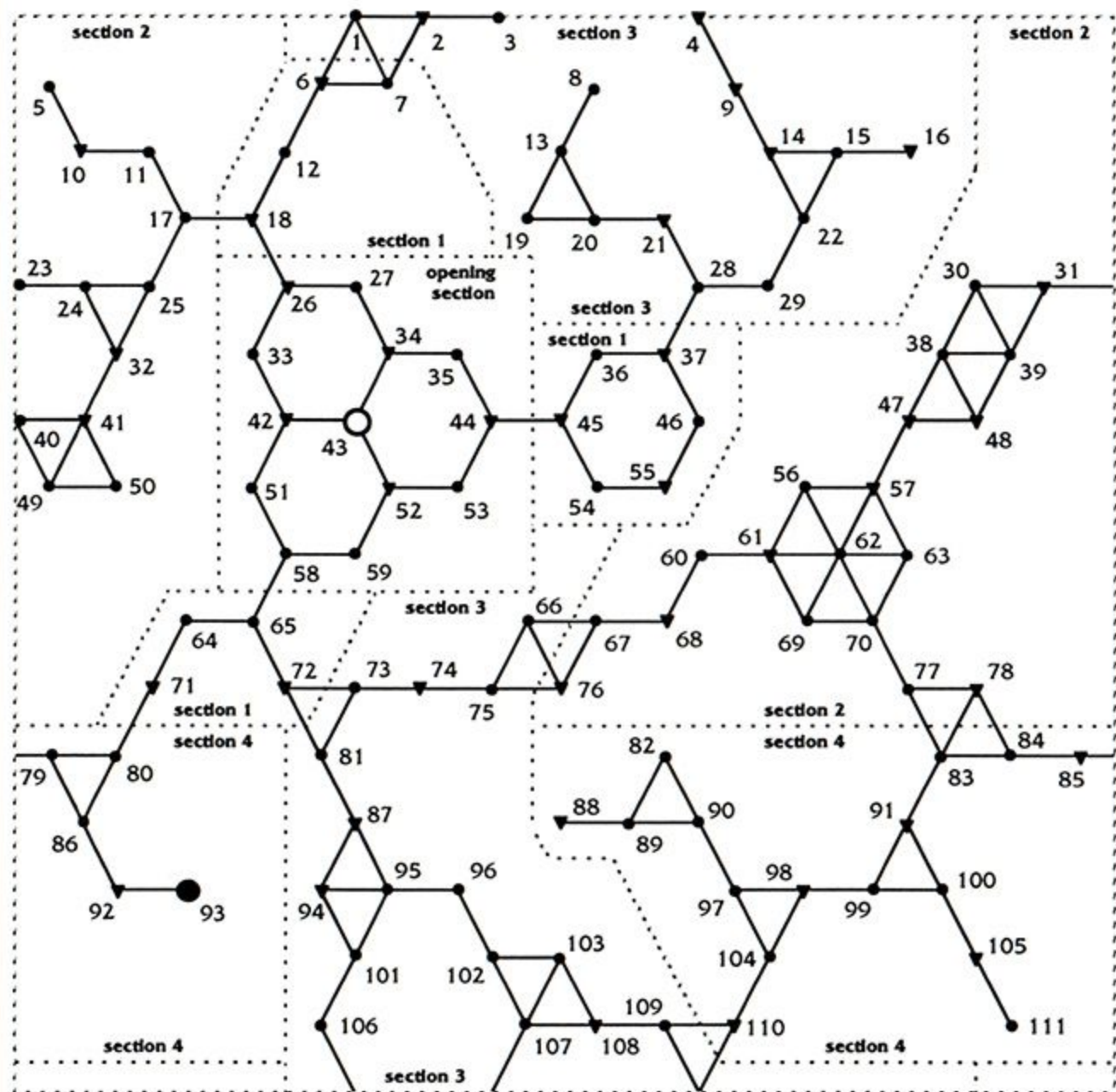

SLUG FLAGSHIP

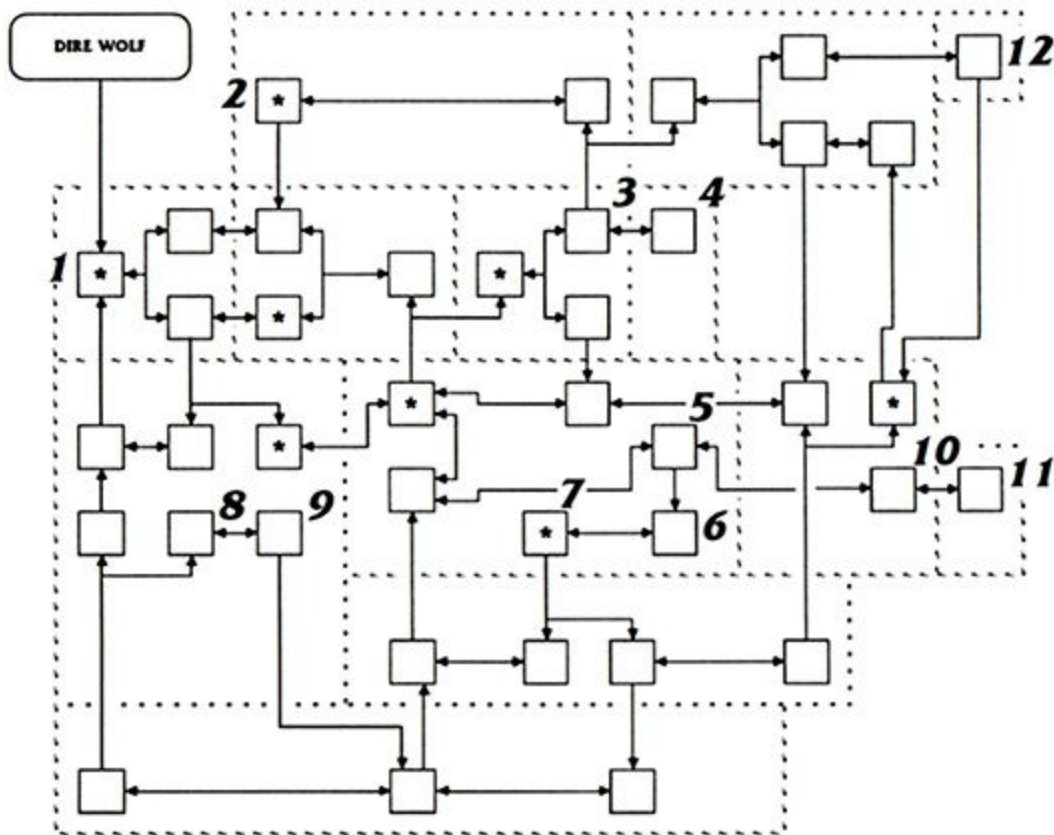

Hints:

- Slugs like to ravel through tubes: use your camouflage module to explore the ship
- Stay alert: vertical tubes are one-way elevators that make backtracking tricky
- There are a number of robots that will betray their Slug masters if you give them trading cards
- If you get lost, beam directly back to the entry room from any transporter square (*)

Here's a list of things to do:

1. Enter here from Dire Wolf—pay Slug robot to open first door
2. Pay Slug robot and get red key
3. Open locked door with red key and thaw secret agent
4. Get blue key from thawed secret agent—clone weapons & fatal signs here
5. If trap door is open, fall through—otherwise walk across
6. Defeat space ship—unlock door
7. Pass thru unlocked door to reach down tube
8. Defeat robot trio—unlock door
9. Pass thru unlocked door—pay Slug robot to close trap door
10. Unlock entrance to weapons research lab with blue key
11. Pay Slug robot and get fatal sign
12. Defeat Slug Lord once and for all with fatal signs!

BIG SKY TROOPER CREDITS

Game Design & Project Lead: HAL BARWOOD
Lead Programmer & Bossman: TONY HSIEH
Programming & Sound: JEFF HALL
Programming & A.I.'s: MARK NADEAU
Planet Geology & Slug Biology: MARK HAIGH-HUTCHINSON
Additional Programming: MARK CROWLEY

Lead Artist & Visual Design: JUSTIN CHIN
Background Art & Animation: TOM PAYNE
Background Art: PATRICK SIRK
Additional Animation: SEAN TURNER
Additional Art: CHRIS HOCKABOUT

Music Composed & Sound Designed by: GREG TURNER
courtesy of REALTIME ASSOCIATES, INC.

Lead Tester: JO "Captain Tripps" ASHBURN
Lead Tester: DARREN JOHNSON

Production Manager: WAYNE CLINE

NOTES

90 DAY LIMITED WARRANTY

JVC Musical Industries, Inc. warrants to the original purchaser of this JMI software product that the medium on which this computer program is recorded is free from defects in materials and workmanship for a period of ninety (90) days from the date of purchase. This JMI software program is sold "as is" without express or implied warranty of any kind, and JMI is not liable for any losses or damages of any kind resulting from the use of this program. JMI agrees for a period of ninety (90) days to either repair or replace, at its options, free of charge, any JMI software product, postage paid, with proof of date of purchase, at its Factory Service Center.

This warranty is not applicable to normal wear and tear. This warranty shall not be applicable and shall be void if the defect in the JMI software product has arisen through abuse, unreasonable use, mistreatment or neglect.

THIS WARRANTY IS IN LIEU OF ALL OTHER WARRANTIES AND NO OTHER REPRESENTATIONS OR CLAIMS OF ANY NATURE SHALL BE BINDING ON OR OBLIGATE JMI. ANY IMPLIED WARRANTIES APPLICABLE TO THIS SOFTWARE PRODUCT, INCLUDING WARRANTIES OF MERCHANTABILITY AND FITNESS FOR A PARTICULAR PURPOSE ARE LIMITED TO THE NINETY (90) DAY PERIOD DESCRIBED ABOVE. IN NO EVENT WILL JMI BE LIABLE FOR ANY SPECIAL INCIDENTAL, OR CONSEQUENTIAL DAMAGES RESULTING FROM POSSESSION, USE OR MALFUNCTION OF THE JMI SOFTWARE PRODUCT.

Some states do not allow limitations as to how long an implied warranty lasts and/or exclusions or limited or incidental or consequential damages so the above limitations and/or exclusions of liability may not apply to you. This warranty gives you specific rights, and you may also have other rights which may vary from state to state.

JVC Musical Industries, Inc.
3800 Barham Boulevard, Suite 305
Los Angeles, CA 90068
1-900-454-4JVC

Big Sky Trooper™ and ©1995 LucasArts Entertainment Company. All Rights Reserved. Used Under Authorization. The LucasArts logo is a registered trademark of LucasArts Entertainment Company.



3800 Barham Blvd., Suite 305
Los Angeles, CA 90068

PRINTED IN USA